

Section 2. Zoning Districts

§2.1 ZONE DISTRICTS ESTABLISHED

In order to implement the *City of Gunnison Master Plan* and promote the purposes of this *Land Development Code*, the following zone districts are established.

TABLE 2-1 BASE ZONE DISTRICTS	
SYMBOL	ZONE DISTRICT NAME
RESIDENTIAL ZONE DISTRICTS	
R-1	Single-Family Residential
R-1M	Single-Family Residential Modified
R-2	Duplex Residential
RMU	Residential Mixed Use
R-3	Multi-Family Residential
NONRESIDENTIAL ZONE DISTRICTS	
B-1	Professional Business
CBD	Central Business
C	Commercial
I	Industrial
SPECIAL PURPOSE AND PLANNED ZONE DISTRICTS	
WSCU	Western State Colorado University
PUD - O	Planned Unit Development - Overlay
PUD - M	Planned Unit Development - Mixed Use

§2.2 ZONE DISTRICT PURPOSE STATEMENTS

A. Residential Zone District Purposes

1. **Single-Family Residential (R-1).** This zone district is established to provide for orderly suburban residential development and redevelopment, and it maintains residential areas at low densities characterized by detached single-family dwelling units.
2. **Single-Family Residential Modified (R-1M).** This zone district is established to provide for residential neighborhoods comprised of detached single-family dwellings on smaller lots than are permitted in the R-1 zone district, allowing for slightly greater overall densities. Areas designated Modified Single-Family Residential (R-1M) includes relatively low density development areas.
3. **Duplex Residential (R-2).** This zone district is established to provide for moderate density residential areas comprised of single-family dwellings and duplex dwellings, with no more than two units permitted in any structure. Two detached single-family dwellings are not allowed on an individual lot, unless one of the dwelling units is an Accessory Dwelling Unit.
4. **Residential Mixed Use (RMU).** This zone district is established to provide for relatively high density single-family, duplex and multi-family residential areas, including primarily triplex, townhouse, and multi-family dwelling uses.
5. **Multi-Family Residential (R-3).** This zone district is established to provide for high density multi-family residential areas and mobile home parks.

B. Nonresidential Zone District Purposes

- 1. Professional Business Zone District (B-1).** This zone district is established to provide for a transitional area between the commercial and residential zone districts, by allowing for relatively lower intensity commercial uses that are compatible with residential uses and maintain the architectural and urban design character of the existing residential neighborhood. Current areas designated Professional Business (B-1) are transitional neighborhoods located adjacent to the Central Business District (CBD) and Commercial (C) zone district.
- 2. Central Business Zone District (CBD).** This zone district is established to provide for the business and civic functions that make up the city core. The Central Business District (CBD) has a strong pedestrian character and provides for concentrated commercial activity, with buildings covering the entire street frontage. It contains a mix of business, commercial and residential uses, and serves the needs of the entire community and those of visitors to the community.
- 3. Commercial Zone District (C).** This zone district is established to provide locations for offices, service uses, hotel accommodations and businesses retailing durable and convenience goods. Upper-floor residential dwellings are allowed. The Commercial zone district is located along the city's main entrance corridors and, therefore, businesses are accessible-to, and serve, the entire community. Site design and buffering mitigate traffic and operations impacts upon adjacent neighborhoods.
- 4. Industrial Zone District (I).** This zone district is established to provide areas for a broad-range of manufacturing, production, product transport, and other industrial uses. These industries should be operated in a relatively clean and quiet manner, and should not be obnoxious to nearby residential or business districts, warehousing and wholesaling activities, and research facilities.

C. Special Zone District Purposes

Western State Colorado University (WSCU). The Western State Colorado University (WSCU) zone district contains the geographic extent of the university real property and campus, with facilities, activity areas, and open space that support related higher education functions. The City and university work together to ensure that the planning and development of the campus is compatible with adjacent municipal uses, that utility service needs are adequately addressed, and that pedestrian and vehicular traffic circulation are designed to efficiently serve the university and community needs.

D. Planned Unit Development





- 1.** A Planned Unit Development (PUD) is a land area such that varying land uses and innovative design and layout of the development provide significant benefits to both the developer and the City over those land use patterns developed and regulated under conventional zoning districts and development standards. Such benefits include the provision of open space for the benefit of the residents and other users, the conservation of natural landscape features, provision of affordable housing, employment opportunities, variety in land use patterns and more efficient provision of services and utilities.

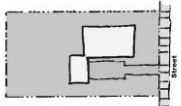

2. In a PUD, the various land use elements are designed so that they interrelate cohesively with each other; therefore, strict application of standard zone district regulations becomes unnecessary instead, other specific development and design requirements are included in the PUD. The boundary between the PUD and adjacent zone districts requires particular attention to ensure that land use patterns are compatible. To enable a more thorough analysis of a PUD, more information is required about the proposal than would be required if development were being pursued within conventional zoning districts.

3. The approval of a PUD constitutes a Zoning Amendment as described in Section 10 of the *LDC* and is established by rezoning an area in an existing zone district to a PUD zone or by initial zoning of newly annexed territory to PUD zoning.

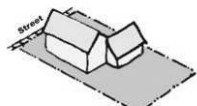
§2.3 DESIGNATED HOUSING TYPES

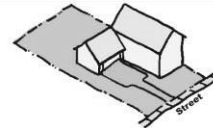
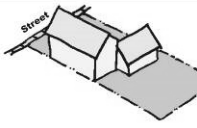
A. Definitions. The following housing types are established to provide a common terminology used in this *LDC*. All drawings are for illustrative purposes only.

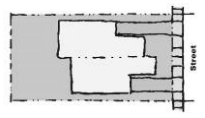
TABLE 2-2 DESIGNATED HOUSING TYPES			
<p>Single-Family Detached or Manufactured Home A detached dwelling unit located on a single lot with private yards on all four sides.</p>			
<p>Zero Lot Line Dwelling A detached dwelling unit located on a single lot with private yards on three sides. The unit has a single side yard on one side comprising the equivalent of two side yards of a single-family detached house. A zero lot line development shall be carried out for an entire block, as a row of units, or as a cluster in order to achieve an overall compatibility of design and so zero lot line dwellings are not situated immediately adjacent to traditionally sited dwellings.</p>			

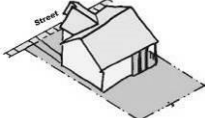
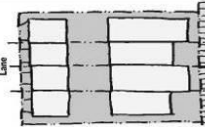
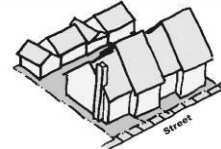
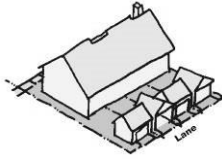
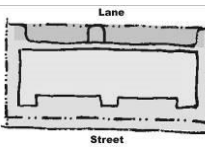
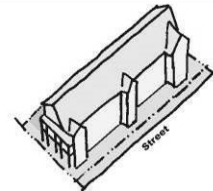
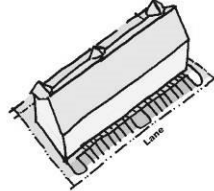
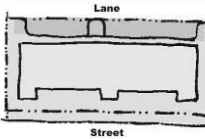
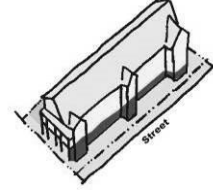
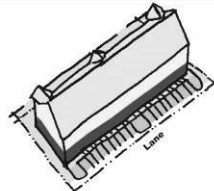
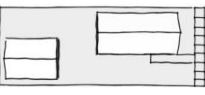
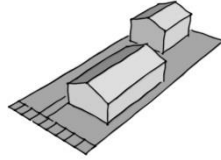
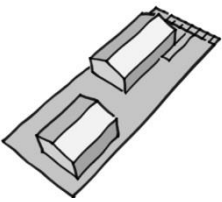
<p>Two-family Dwelling</p> <p>Two attached dwelling units in a single structure on a single lot (often called a duplex). The two units can be located on separate floors or side-by-side.</p>			
<p>Townhouse</p> <p>Two or more attached dwelling units located on separately owned lots or on a single lot. The units are lined up in a row and share side walls. Dwelling units cannot be mixed vertically.</p>			
<p>Multi-Family</p> <p>Three or more attached dwelling units in a single structure on a single lot. A multi-family dwelling can vary in height from two to three stories. Dwelling units can be mixed vertically.</p>			
<p>Upper-Story Residential</p> <p>A dwelling unit located on a floor above a nonresidential use.</p>			
<p>Accessory Dwelling Unit</p> <p>A dwelling unit with a floor area between 300 and 720 square feet and is located on the same site as, but have a separate entrance from, a single-family dwelling.</p>			

B. Manufactured Housing. Manufactured homes are factory-built dwelling units, manufactured or constructed to comply with the standards of the *National Manufactured Housing Construction and Safety Standards Act of 1974*. Manufactured homes shall meet the standards of §3.3 (Residential Use Standards). Any manufactured home which does not meet any of the standards of §3.3 shall be considered a mobile home, and shall comply with all standards of this *LDC* applicable to such use.

C. Mobile Home. “Mobile home” means a dwelling which is eight feet or more in width and 40 feet or more in body length, is designed to be transported on its own permanent chassis after fabrication, and which is designed to be used as a dwelling, with or without permanent foundation, when the required plumbing, heating, and electrical facilities are connected. Mobile homes shall comply with one of the following circumstances.

- 1. Comply with HUD Code.** New or used mobile homes installed after the effective date of this *LDC* shall comply with the standards of the *National Manufactured Housing Construction and Safety Standards Act of 1974* (hereinafter referred to as “the *HUD Code*”). Such mobile homes shall have a roof capable of bearing a minimum 40-pound snow load.
- 2. Pre-date HUD Code.** Mobile homes built prior to the *HUD Code* shall have a roof capable of bearing a minimum 30-pound snow load.

§2.4 PRINCIPAL USE TABLE

- A. Permitted Uses.** A “P” indicates that a use is allowed by right in the respective zoning district and may be reviewed and approved by the Director. Permitted uses are subject to all other applicable regulations of this *LDC*.
- B. Conditional Uses.** A “C” indicates that a use is allowed only if reviewed and approved as a Conditional Use, in accordance with the Conditional Use review procedures of Section 7 (Conditional Uses). Conditional Uses are subject to all applicable regulations of this *LDC*.
- C. Uses Not Allowed.** A blank cell indicates that a use is not allowed.
- D. Specific Use Standards.** The final column titled “Use Standards” contains a cross-reference to related standards established in Specific Use Regulations, of this *LDC*. Where no cross-reference is shown, no additional use standard shall apply.
- E. Uses Not Listed.** The Director shall use the criteria in §3.1 to determine how an unlisted use should be treated.

TABLE 2-3 PRINCIPAL USE TABLE											
Use Categories	Specific Uses	RESIDENTIAL ZONING DISTRICTS					NON-RESIDENTIAL ZONING DISTRICTS				Use Standards
		R-1	R-1M	R-2	RMU	R-3	B-1	CBD	C	I	
Residential Use Categories (§3.2)											
Household Living	Accessory Dwelling ¹			P	P	P	P	P	P	P	§3.3H
	Duplex dwellings			P	P	P	C		C		§3.3C
	Manufactured homes	P	P	P	P	P	P	C	C		§3.3B
	Mobile home parks					C					§3.3I
	Multi-family dwellings				P	P	C		C		§3.3D
	Single-family dwellings	P	P	P	P	P	P	C	C		§3.3 C
	Townhouses				P	P			C ²		§3.3F
	Upper story residential ¹						P	P	P	P	§3.3G
Congregate Living	Zero lot line dwellings			P	P	P					§3.3E
	Assisted Living homes	C ³	C ³	C ³	C ³	C ³			C ³		§3.3J
	Nursing home			C	C	C			C		§3.3J
Home Occupation and Home Business	Rooming and boarding houses, dormitories, fraternities or sororities				C	C					§3.3K
	Home Occupation	P	P	P	P	P	P	P	P		§3.3L
Home Business	Home Business	C	C	C	C	C	P	P	P		§3.3L
	Marijuana										
	Personal Use of Marijuana	P	P	P	P	P	P	P	P	P	§3.3M
Public, Civic and Institutional Use Categories (§3.4)											
Community Service	Detention Center									P	--
	Mausoleum, columbarium	C	C	C	C	C	C	C	P		--
	Neighborhood or community centers	C	C	C	C	C	P		P		--
	Public garage or shop									P	--
Educational Facilities	School, public or private	C	C	C	C	C	C	C	C		§3.4A
	School, trade or business	C	C	C	C	C	C	C	C	C	
Day Care	Daycare Center			C	C	C			C ²		§3.5A
	Daycare Home	C	C	P	P	P	P	P	P	C	
	Daycare School			C	C	C	C	C	C	C	
Marijuana-Related Business	Marijuana Club or Vapor Lounge ⁴										--
Medical	Hospitals						C		P		--
Parks and Open Space	Parks and recreational facilities	P	P	P	P	P	P	P	P	P	--
Religious Institutions	Churches or places of worship	C	C	C	C	C	C	C	P		§3.5B
Utilities	Major utilities (private only)	C	C	C	C	C	C	C	C	P	--
	Minor utilities	P	P	P	P	P	P	P	P	P	--
Accommodation, Retail, Service - Commercial Use Categories (§3.6)											
Entertainment Event, Major	Auditoriums							C	P	P	--

¹ See special allowances in the Use Standards.

² Ordinance 4, 2014

³ Conditional Use is limited to not more than eight developmentally disabled or eight mentally ill persons pursuant to CRS §31-23-304(4).

⁴ Ordinance 5, 2015

TABLE 2-3 PRINCIPAL USE TABLE												
Use Categories	Specific Uses	RESIDENTIAL ZONING DISTRICTS					NON-RESIDENTIAL ZONING DISTRICTS				Use Standards	
		R-1	R-1M	R-2	RMU	R-3	B-1	CBD	C	I		
	Fairgrounds									P	--	
Office	Banks and financial institutions						C	P	P	P	--	
	Government offices					C	P	P	P	P	--	
	Medical clinic or dental office						P	P	P		--	
	Professional offices						P	P	P	C	--	
	Radio and television studios						P	P	P		--	
Parking, Commercial	Commercial parking lots and garages							C	P	P	--	
Retail Sales, Rental and Service, Sales-Oriented	Art Galleries						P	P	P		--	
	Auto sales and rental								P	P	--	
	Automotive Supplies								P	P	--	
	Book stores						P	P	P	C	--	
	Convenience Stores, without gas pumps							P	P	P	--	
	Drive-in						C	C	C	C	§3.12B	
	Furniture and Appliance Stores							P	P	P	--	
	Greenhouse or nursery						C	C	P	P	--	
	Lumber and building material sales								C	P	--	
	Outside Sales or Display							C	P	P	§3.7 B.3.	
	Recreational Vehicle Sales								P	P	--	
	Retail Grocery Store						C	C	P	C	--	
Retail Sales and Service, Personal Service-Oriented	Athletic or Health Clubs						P	P	P	P	--	
	Barber and beauty shops						P	P	P		--	
	Drive-in						C	C	C	C	§3.12.B.	
	Dry cleaning drop-off/pick-up						P	P	P	P	--	
	Funeral homes and mortuaries							C	P	P	--	
	Kennels								C	P	--	
	Laundromats					C			P	P	--	
	Photography studios						P	P	P	P	--	
Veterinary clinic								P	P	--		
Marijuana ⁵	Retail Marijuana								P	C	§3.15	
	Medical Marijuana Centers								P	C	§3.15	
Accommodations	Bed and breakfasts				C	C	C	C	P ⁶		§3.7 A.1.	
	Hostels				C	C	C	C	P		§3.7 A.2.	
	Hotels and motels							C	P		§3.7 A.3.	
	RV Parks					C			C	C	§3.7.A.4.	
Retail Sales and Service, Eating and Drinking –Oriented	Bars and taverns							P	P	C	--	
	Coffee shop/bakery						C	P	P	P	--	
	Drive-in							C	C	C	§3.12 B.	
	Restaurants						P	P	P	C	--	

⁵ Ordinance 5, 2015

⁶ Ordinance 3, 2015

TABLE 2-3 PRINCIPAL USE TABLE												
Use Categories	Specific Uses	RESIDENTIAL ZONING DISTRICTS					NON-RESIDENTIAL ZONING DISTRICTS				Use Standards	
		R-1	R-1M	R-2	RMU	R-3	B-1	CBD	C	I		
Retail Sales and Service, Entertainment-Oriented	Private lodges and clubs							P	P	C	--	
	Recreation, indoor							P	P	C	--	
	Theater							P	P	P	--	
Retail Sales and Service, Repair-Oriented	Appliance repair							C	P	P	--	
	Bicycle repair/rental						P	P	P	P	--	
	Locksmith						C	P	P	P	--	
Vehicle Services, Limited	Car washes								P	P	--	
	Convenience stores, with gas pumps							C	P	P	§3.7 B.1.	
	Service stations								P	P	--	
Industrial Use Categories (§3.8)												
Industrial Sales and Service	Agricultural implement sales/service								P	P	--	
	Building and heating contractors								P	P	--	
	Chemicals or explosives manufacture									C	--	
	Dry cleaning/dyeing plant							C	P	P	--	
	Feed and grain sales								P	P	--	
	Manufactured home sales/service								C	P	--	
	Repair and service of industrial vehicles								C	P	--	
	Research laboratories								C	P	--	
	Salvage or wrecking yards, or junkyards									C	--	
	Sale, rental, leasing of heavy equipment								C	P	--	
	Truck Stop								C	P	--	
Manufacturing and Production	Catering Services						C	P	P	P	--	
	Concrete or redi-mix plant									P	--	
	Firewood Production ⁷								C	P	--	
	Greenhouse/nursery							C	P	P	--	
	Industrial Hemp Production									P	--	
	Manufacture or assembly of machinery, equipment, instruments								C	P	--	
	Meat Processing									C	--	
	Printing, publishing and lithography						C	P	P	P	--	
Woodworking and cabinet shops								C	P	--		

⁷ Ordinance 4, 2014

TABLE 2-3 PRINCIPAL USE TABLE												
Use Categories	Specific Uses	RESIDENTIAL ZONING DISTRICTS					NON-RESIDENTIAL ZONING DISTRICTS				Use Standards	
		R-1	R-1M	R-2	RMU	R-3	B-1	CBD	C	I		
Marijuana Manufacturing and Production ⁸	Marijuana manufacturing										P	§3.15
	Medical marijuana-infused products manufacturing										P	§3.15
	Marijuana cultivation										P	§3.15
	Medical marijuana optional premises cultivation operation										P	§3.15
	Marijuana testing facility									P	P	§3.15
Self-storage Warehouse	Mini-warehouses and mini-storage										P	--
Vehicle Repair	Auto body shops									C	P	§3.7.B.2
	Auto, truck and boat repair									C	P	§3.7.B.2
	Quick lube service									P	P	§3.7.B.2
Warehouse and Freight Movement	Air cargo terminal										P	--
	Outdoor storage, general									C	P	§3.9B.
	Post Office								P	P	P	--
	Recreational vehicle storage									C	P	§3.9B.
	Utility service yards or garages									C	P	§3.9B.
Waste-Related	Warehouses and truck terminals										P	§3.9B.
	Transfer stations										P	--
Wholesale Sales	Recycling centers										P	--
	Mail order houses							P		P	P	--
Wholesale Sales	Wholesalers of food, clothing, and parts									C	P	--
	Other Uses Categories §3.10											
Adult entertainment	Sexually oriented businesses										C	§3.10 C.
Alternative Energy	Solar Voltaic and Wind Turbines	C	C	C	C	C	C	C	C	C	C	§3.11 D.
Aviation and Surface Transportation	Airports and related facilities, public										P	§3.11 A.
Mining	Processing of aggregate mineral or other subsurface resources										C	§3.11 E.
	Asphalt Batch Plant										C	§3.11 E.
Telecommunications Facilities	Telecommunications facilities and towers								C	C	P	§3.11 B.
Temporary Commercial Activity	General retail sales or other commercial use operated outside of a building on a seasonal basis.								C	C	C	§3.13

§2.5 BASE PRINCIPLE USE CATEGORIES

A. Authority. If an application is submitted for a use type not listed the Principal Use Table (§2.4),

⁸ Ordinance 5, 2015

the Director shall be authorized to make a similar use interpretation, based on the following considerations:

1. the actual or projected characteristics of the activity in relation to the use category cited in the Principal Use Table (§2.4);
2. the relative amount of site area or floor space and equipment devoted to the activity;
3. relative amounts of transaction volume from each activity;
4. the customer type for each activity;
5. the number of employees in each activity;
6. hours of operation;
7. noise and odor generation;
8. architectural mass and form;
9. site design and arrangement;
10. parking demand;
11. vehicles used with the activity;
12. the relative number of vehicle trips generated by the use;
13. delivery volume;
14. signs;
15. how the use advertises itself;
16. whether the activity is likely to be found independent of the other activities on the site; and
17. effect of the proposed use on uses adjacent to the site.

B. Use Interpretation Standards

1. No use interpretation shall allow a use in a zone district when that use is a Permitted or Conditional Use in any other zone district.
2. No use interpretation shall permit any use in any zone district unless evidence is presented demonstrating that it will comply with all applicable requirements and standards of this *LDC*.
3. No use interpretation shall permit any use in a zone district unless said considerations cited above demonstrate that the use in question is roughly proportional to Permitted and Conditional Uses in the underlying zone district.
4. If the proposed use is more similar to a use allowed only as a Conditional Use in the zone district in which it is proposed to be located, then any similar use interpretation permitting that use shall require a Conditional Use Permit, as appropriate.

C. Use Interpretation Effect. No similar use interpretation finding a particular use to be permitted or conditionally permitted in a specific zone district shall authorize the establishment of such use or the development, construction, reconstruction, alteration, or moving of any building or structure, but shall merely authorize the preparation, filing, and processing of applications for any permits

and approvals that may be required by this *LDC* and ordinances of the City of Gunnison. Permits and approvals include, but are not limited to: Conditional Use permits, development permits, building permits, and building certificates of occupancy.

§2.6 BASE ZONE DISTRICT DIMENSIONAL STANDARDS

A. Intent. The base zone district dimensional standards establish maximum density and intensity, lot sizes, height standards, and lot coverage criteria for all development applications. These standards allow for variety in housing types while maintaining the overall character of neighborhoods and commercial areas of the city. Separate standards are established to regulate development in each base zone district. This approach to zone district development standards promotes development intensities that match existing and proposed infrastructure investments.

B. Dimensional Standards - Residential Zone Districts

- 1. Development Standards.** Development applications shall comply with all applicable development standards as set forth in this *LDC* and other applicable laws.
- 2. Dimensional Standards.** Development applications shall comply with the following dimensional and all other provisions in this *LDC* and other applicable laws.

TABLE 2-4 RESIDENTIAL DIMENSIONAL STANDARDS					
Dimensional Standard	R-1	R-1M	R-2	RMU	R-3
Maximum density (units/acre) ¹	3.5	6	14	16	30
Lot Size Single-Family (sq. ft.) ¹	8,000	6,250	6,250	6,250	6,250
Lot Size Duplex (per unit) (sq. ft.) ¹			3,125	3,125	3,125
Lot Size Townhouse (per unit) (sq. ft.) ³				2,250	2,250
Lot Size Multi-Family (per unit) (sq. ft.) ¹					
Single Story				3,000	3,000
Two Story				2,500	2,500
Three Story				2,000	2,000
Maximum lot coverage structures	40%	40%	40%	45%	45%
Maximum lot coverage parking/access	10%	10%	15%	20%	40%
Minimum lot coverage landscape area	50%	50%	45%	35%	15%
Minimum lot frontage ¹					
Single-Family	50'	50'	50'	50'	50'
Duplex (per unit)			25'	25'	25'
Townhouse (per unit) ³				20'	20'
Multi-Family				100'	100'
Zero-Lot Line	50'	50'	50'	50'	50'
Minimum setback front²	15'	15'	15'	15'	15'
Minimum setback side Provided that one additional foot of setback shall be required for each two and one-half feet (a 1:2.5 ratio) of building height over 22.5 feet	10'	5'	5'	5'	5'
Minimum setback rear lot line: principal building Provided that one additional foot of setback shall be required for each two and one-half feet (a 1:2.5 ratio) of building height over 22.5 feet	10'	5'	5'	5'	5'
Minimum setback rear lot line: accessory building	10'	5'	5'	5'	5'
Maximum building height	35'	35'	35'	35'	35'

TABLE 2-4 RESIDENTIAL DIMENSIONAL STANDARDS					
Dimensional Standard	R-1	R-1M	R-2	RMU	R-3
Maximum building height for detached accessory structure	30'	30'	30'	30'	30'
Minimum building width	24'	24'	20'	20'	20'
Minimum floor area Principal Dwelling (sq. ft.)	480	480	480	300 efficiency	300 efficiency
				480 multi-family	480 multi-family
Floor Area Thresholds Accessory Dwelling (sq.ft.)				720	
Minimum storage area (sq.ft.)			32	32	32
Snow storage (% of parking and access coverage)	15%	15%	15%	15%	15%

¹ Density calculations for residential development may be subject to Slope Protection Standards (§5.2) and Section 13.
² Covered porches and the landings and steps of a covered porch may encroach into the front yard pursuant to §1.7.L.3.d
³ Ordinance #3, Series 2016

3. Solar Access Standards. In order to facilitate reasonable solar access for all residential properties, side and rear setback, and height standards in all residential districts are subject to certain limitations set forth herein.

- a. **Exception.** Development which includes 25 percent or more affordable dwelling units as established in §13.7. D. of this LDC shall be exempt from solar access height limitations.
- b. **One- and Two-Story Dwellings.** One- and two-story dwellings within any residential district shall be designed and constructed so as not to cast a shadow greater than a 22.5 foot-tall hypothetical wall located along the side and rear property lines, at noon MST on December 21st.

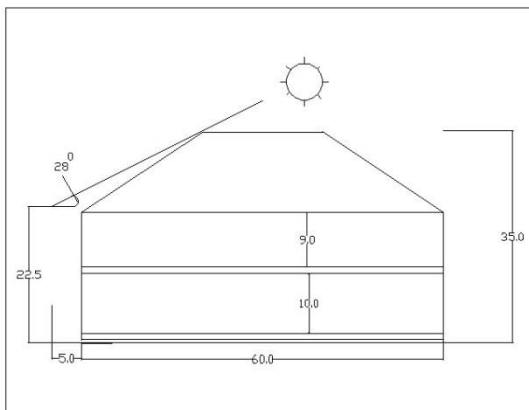

FIGURE 5 TWO-STORY HIP ROOF MEETING SOLAR ACCESS STANDARDS

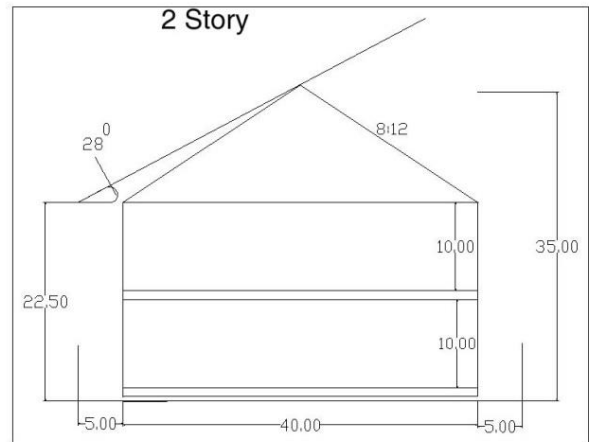

FIGURE 6 TWO-STORY GABLE-END ROOF MEETING SOLAR ACCESS STANDARDS

- c. **Three Story Dwellings.** Three-story dwellings in any residential district shall be designed and constructed so as not to cast a shadow greater than a 22.5 foot-tall hypothetical wall located along the side and rear property lines, at noon MST on December 21st. Furthermore, any portion of such three story dwellings shall be setback from interior (side or rear lot line) north lot lines an additional 1 foot, beyond the minimum required, for each 2.5 feet or fraction thereof of exceeding 22.5 feet in height. For the purpose of application any side or rear lot line that has a bearing less than or equal to 30° from true east or west shall be considered a north boundary.

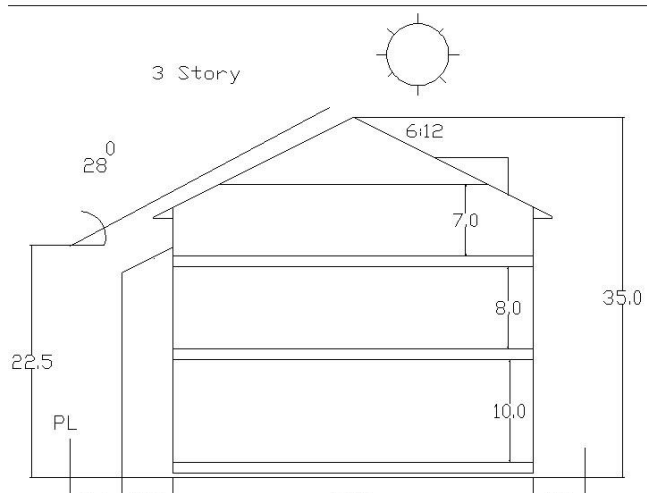

FIGURE 7 THREE-STORY MEETING SOLAR ACCESS STANDARDS

- d. **Alternative Compliance.** Upon request by an applicant, the Community Development Director may approve an alternative site layout that may be substituted in whole or in part for a plan meeting the standards of this Section.
- i. **Procedure.** Alternative compliance plans shall be prepared and submitted in accordance with submittal requirements for plans as set forth in this Section. The plan shall clearly identify and discuss the modifications and alternatives proposed and the ways in which the plan will better accomplish the purpose of this Section than a plan which complies with the standards of this Section.
- ii. **Review Criteria.** In approving an alternative plan, the Community Development Director shall find that the proposed alternative plan accomplishes the purposes of this Section equally or better than a plan which complies with the standards of this Section, or that site conditions including but not limited to lot size, lot configuration, topography are such that reasonable use of the property is precluded by the application of these solar access standards.

C. Dimensional Standards - Nonresidential Zone Districts

1. **Development Standards.** Development applications shall meet all applicable development standards as set forth in this *LDC* and all other applicable laws.
2. **Nonresidential Dimensional Standards.** Permitted nonresidential uses shall meet the following dimensional standards. Development applications for non-residential uses shall comply with all other provisions of this *LDC* and all other applicable laws.
3. **Upper-Story Residential Dwellings.** Upper-story residential units are permitted on the upper floors of nonresidential buildings, but shall conform to all lot, yard and bulk requirements of the principal building.

TABLE 2-5 NONRESIDENTIAL ZONE DISTRICT DIMENSIONAL STANDARDS				
STANDARD	B-1	C	CBD	I
DENSITY				
Max. density (units/acre)	7	14	NA	7
LOT				
Minimum lot size (sq. ft.)	6,250	8,000	--	6,250
Minimum lot frontage (ft.)	50	50	--	50
Maximum lot coverage: (%) structures	40	50	100	60
Maximum lot coverage: (%) Parking Access	15	40	N/A	30
Minimum landscape area (%)	45	10	--	10
BUILDING				
Maximum building height (ft.)	35	35	35	35
Minimum building width (ft.)	24	--	--	--
Minimum floor area: Multi-family (sq. ft.)	480	300 efficiency 480 multi-family	--	--
Minimum floor area: Second story residence (sq. ft.)	300	300	300	300 min 700 max
Minimum storage area (sq. ft.) ¹	32	32	32	--
BUILDING SETBACKS				
Minimum from side lot line (ft.)	5	5 ²	no. req.	5 ¹
Minimum from rear lot line (ft.) principal building	5	5 ²	no req.	5 ²
Minimum from rear lot line (ft.) accessory building	5	5 ²	N/A	N/A
Minimum from front lot line (ft.)	15 ³	15 ²	no req.	0 ²
Other Standards				
Snow Storage Area (% of parking and access coverage)	15	15	N/A	15
¹ Storage is required for multi-family dwellings) (§3.3D)				
² Uses adjacent to residential zone districts shall comply with Zone District Buffer Standards (§4.6 F. 3).				
³ Parking not allowed within front setback area in B-1 Zone District				

§2.7 WESTERN STATE COLORADO UNIVERSITY STANDARDS

- A. Applicability.** Western State Colorado University (WSCU) zone district standards apply to related properties identified on the Official Zoning Map.
- B. Allowed Uses.** Uses allowed in the WSCU zone district are those pertinent to the operations of Western State Colorado University.
- C. Zone District Standards.** District standards applicable in the WSCU zone district shall be those established and regulated by the State of Colorado.